

	PART NAME	Q'TY	REMARK
A	Control Room	1	
B	Motor	1	
C	Hand Wheel	1	
D	Terminal Compartment	1	
E	Hand Auto Lever	1	
F	Cable Entries	3	

NOTE

- 1
- 2

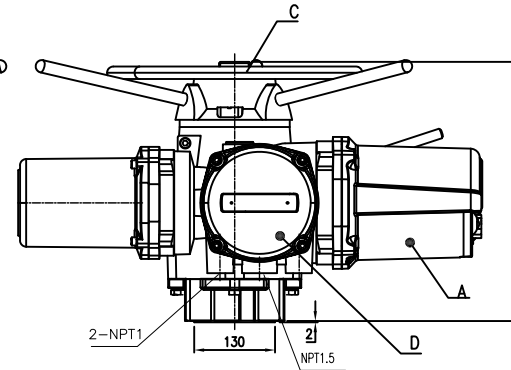
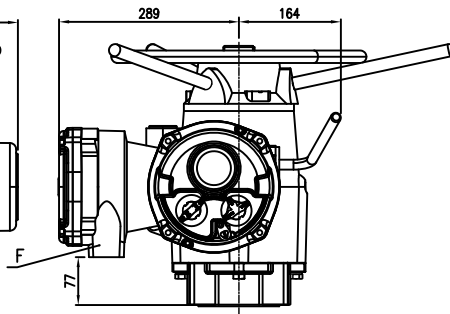
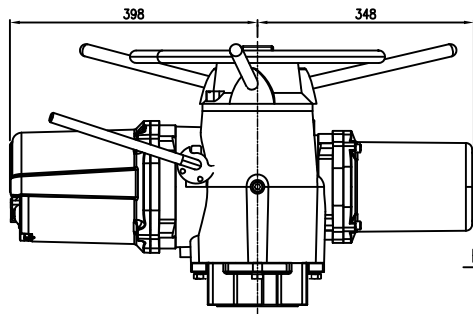

"d" is the max diameter of the Stem
 d=51 (Keyed shaft)
 d=67 (threaded stem)
 d=69 (shaft clearance)

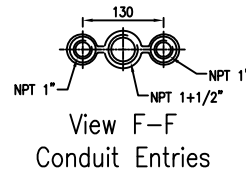
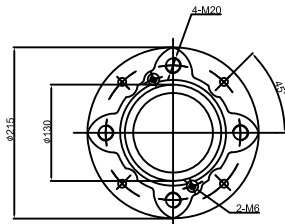
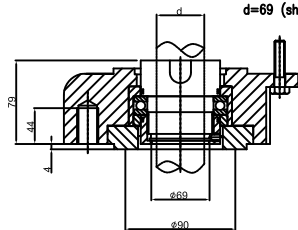

F16 Type Z Coupling and Base details

NEWTORK NEWTORK KOREA CO., LTD.

DATE 2024-07-15	REV. 2	DWG TITLE NTI SERIES LAYOUT DRAWING NTI-06
DRWN. J.W. CHAE	SHEET NO. 1 OF 1	
CHKD. Y.S. KIM	SCALE 1 : 1	DWG NO. NTK-QP-103-Z
APRD. E.M. HUH		